

# 2012

## Apostle Islands Station of the Wayzata Yacht Club Notice of Race and Sailing Instructions

### Starting Sequence

Skippers Meeting	Approximately 10:00 AM via VHF Radio Channel 72 Course information posted on Committee Boat prior to start
First Race	Warning signal at approximately 11:00 AM
Succeeding Races	Warning signal approximately 20 minutes after conclusion of previous race

### Notes

Times shown are examples of standard times; see schedule for actual Warning times

<b>Fleet Captain</b>	Bill Peterson	Work 952-937-3915 Cell 612-247-5335 Home 715-779-3419 <a href="mailto:william.s.peterson@rrd.com">william.s.peterson@rrd.com</a>
----------------------	---------------	---

<b>Fleet Treasurer</b>	Mike Spence	Work 612-335-2708 Cell 612-600-8969 <a href="mailto:Mike.Spence@k-a-c.com">Mike.Spence@k-a-c.com</a>
------------------------	-------------	--

<b>Race Judge</b>	Corey Bakken	Home 715-779-9850 <a href="mailto:coreybakken@hotmail.com">coreybakken@hotmail.com</a>
-------------------	--------------	---

<b>WYC Board Representative</b>	Chris Nimmer	Home 763-522-6765 Cell 612-598-6815 <a href="mailto:nimmer.christopher@gmail.com">nimmer.christopher@gmail.com</a>
---------------------------------	--------------	--

<b>Race Week Registration and Communications</b>	Jim Vaudreuil	Home 715-835-1490 Cell 715-210-5263 Bayfield 715-779-0204 <a href="mailto:jimv@huebsch-services.com">jimv@huebsch-services.com</a>
--	---------------	---

## **1.0 Rules**

- 1.1 Racing will be governed by the Racing Rules of Sailing, the prescriptions of the United States Sailing Association, and the PHRF class (except as any of these are altered by these Sailing Instructions, or by the local fleet and filed with the Race Committee Chair prior to the beginning of racing) and these sailing instructions. Wayzata Yacht Club (WYC) races are a category B event. All advertising must be submitted in writing to the WYC board of directors at a regular board meeting for approval, which approval, if given, must be in writing to the boat owner before the boat can display any advertising.

## **2.0 Entries**

- 2.1 Eligible boats for the AIS series may be entered by completing registration with the WYC, the appropriate fleet, and paying all required fees. Guest racers and cruisers must register on line, or by contacting the registration officer on page 1, and pay the appropriate fee.
- 2.2 AIS Eligible boats are required to have a “Family” or “Annual” member of WYC on board for each race. This changes Rule 46 and RRS75.1.
  - 2.2.1 Instruction 2.2 to the contrary notwithstanding, a boat may substitute a paid WYC Crew Member for the required Family or Annual Member in up to three races per season, provided that the prior notice of the substitution is given to the Fleet Captain.
  - 2.2.2 Each paid WYC Crew Member may substitute for a Family or Annual Member on board no more than three times per season.
- 2.3 Eligibility requirements for boats are:
  - 2.3.1 Each shall be a member of PHRF or other class as the WYC may recognize.
  - 2.3.2 All boats shall carry adequate liability insurance, and provide proof of this insurance upon request.
  - 2.3.3 All boats shall have required safety gear, proper government registration, display licenses, numbers etc. as required by law, and comply with Category 4 safety requirements as published by US Sailing.
  - 2.3.4 From the time the boat sails near the racing area prior to racing, and while racing, and until a boat leaves the racing area after racing, transom mounted engines shall be stowed aboard or left mounted with the shaft in the vertical position.
  - 2.3.5 All boats shall have a copy of the Racing Rules of Sailing including the prescriptions of the United States Sailing Association, or a facsimile that gives the same information.
  - 2.3.6 Any boat using a borrowed sail shall report the proper sail number to the Committee Boat both prior to starting and after finishing each race where a borrowed sail is used.
  - 2.3.7 Apostle Islands boats (AIS) shall hold a valid and current PHRF rating as issued by the Lake Michigan PHRF (LMPHRF) organization. It

is the burden of each owner to convey this certificate to the Race Committee prior to racing. In absence of a current and valid rating certificate, temporary ratings may be assigned by the Race Committee and such a rating will be arbitrary and punitive. Temporary ratings are not appealable, and shall govern all races until a valid and current LMPHRF certificate is issued to the race committee.

### **3.0 Notice to Competitors**

3.1 Official notices to competitors will be posted on the Notice Board located at the Dock Office of the Apostle Islands Marina.

### **4.0 Changes in Sailing Instructions**

4.1 Changes to the Sailing Instructions shall be posted on the notice board two hours prior to the first race of the day or shall be announced by the race committee on VHF 72 prior to the warning signal of a race per RRS89.2

4.2 There will be an unofficial announcement by the Race Committee in channel 72 at 10:00 am of each race day (except Race Week) with the general information on that day's race(s) location and other social type events.

### **5.0 Signals**

5.1 Signals made ashore will be displayed by the committee boat.

5.1.1 Flag "AP" with two sound signals (one sound signal when lowered) means; the race is postponed. The warning signal will be made in less than one hour after the "AP" is lowered.

5.1.2 Flag "N" over "C" means: Scheduled races are cancelled.

5.2 Special signals in the racing area:

5.2.1 Flag "N" over "C" means: Scheduled races are cancelled.

5.2.2 Flag "S" is the "Shortened Course" Signal. When made

a) at the starting line:

The Time limit has been changed to 2.5 hours for all classes and a course with shorter than normal legs has been set. No sound signal.

b) at a mark when the Committee Boat is displaying a blue flag:

Some or all of the classes not expecting to finish on this leg are finishing between the mark and the Committee Boat. Listen for a vocal hail of affected classes and course. Repeat sound signals.

c) at any other time:

Course has been shortened. Listen for vocal hail of affected classes and course. Repeated sound signals.

### **6.0 Schedule of Races**

6.1 Races are scheduled as shown in "The Schedule of Races" attached. Races are scheduled as shown in "The Schedule of Races" attached.

6.2 Up to 3 races may be sailed on a race day that precedes another race day. The last warning signal will not be made after 3:00 PM.

6.3 Up to 2 races may be sailed on a race day that does not precede another race day. The last warning signal will not be made after 2:00 PM.

6.4 The sailing of subsequent races will be announced by the Race Committee on VHF 72.

6.5 The schedule of races for Bayfield Race Week shall be according to Bayfield Race Week Sailing Instructions.

## 7.0 Class Flags

7.1 None

## 8.0 Racing Areas

8.1 The racing area will be in and around the Apostle Islands.

## 9.0 The Course(S)

9.1 The diagram in illustration “B” attached shows the courses, including the approximate angles between legs, the order in which marks are to be passed, and the side on which each mark is to be left. In buoy course racing, Mark 1 will be approximately 1 to 3 miles from Mark 3.

9.2 Courses will be designated on a display board on the Committee Boat for each class by letter and number. Courses will be made up of combinations of “T” for triangle, “W” for windward/leeward and/or “O” for Olympic which make up the elements of a complete course (see Illustration B). If no number follows the letter, sail that element one time. If a number follows a letter, sail that element of the course that many times.

9.3 The approximate compass bearing and distance from the starting line to Mark 1 will be displayed from the Committee Boat.

## 10.0 Marks

10.1 Marks will normally be red or orange spheres, though white or green may be used. The Starting Mark will be the same as Mark 3. An offset mark smaller than Mark 1 may be used near Mark 1 and is a Mark of the Course to be passed after and on the same side as Mark 1.

10.2 All boats shall obey all navigational buoys while racing, except if the navigation buoy is a mark of the course, when such navigation buoy may be rounded pursuant to the Race Instructions.

## 11.0 The Start

11.1 Races will be started as follows:

Signal	Flag	Minutes before starting signal
Warning	Yellow	10
Preparatory	Blue	5
Start	Red	0

This changes Rule 26. The preparatory signal for each succeeding class shall be made with or after the starting signal of the preceding class.

11.2 The starting line will be between a staff displaying an orange flag or shape on the Committee Boat and Mark 3 (or the special starting mark described in Instruction 10.10). Rule 27.2 is changed to allow the PRO to adjust the starting line at any time.

11.3 Recalls will be signaled as follows:

11.3.1 Individual recalls will be signaled in accordance with Rule 29.1 with one sound signal sounded for each boat recalled. Every attempt will be made to vocally and by VHF radio on channel 72, hail each boat being recalled. This changes Rule 29.1. A boat that does not respond to her individual recall shall be scored OCS (on the course side).

11.3.2 General recalls will be signaled in accordance with Rule 29.2. Two sound signals will be made upon signaling. There will be no sound signal upon lowering. The Class recalled shall always go to the end of the starting order and start 5 minutes after the last Class started. "First Substitute" will be flown no more than 2 minutes after the start signal. This changes Rule 29.2.

## **12. Cancellation**

12.1 Races will be cancelled or postponed when the 5-minute mean wind speed exceeds 24 knots or wind gusts exceed 30 knots as determined by the race judge. If this condition exists 1 hour before the start, signals will be made ashore. If this condition develops less than one hour prior to the start, signals will be made by the committee boat.

12.2 Should the 5-minute mean wind speed exceed 20 knots but not 24 knots the race judge will change the course to a random course. Racers, who hold a valid and current LMPHRF certificate, may radio the race judge and announce their intention to race without spinnakers. The Race judge will notify the scorer after the race so that the appropriate rating is used.

## **12.0 Change of Course After the Start**

13.1 A change of course after the start will be signaled before the leading boat has begun the leg, although the new mark may not be in position. Any mark to be rounded after rounding the new mark may be relocated to maintain the original course configuration.

13.2 The Race Committee will not display the minus (-) sign or the plus (+) sign described in Rule 33. This changes Rule 33.

## **13.0 The Finish**

14.1 The finishing line will be between a staff displaying an orange flag on a Race Committee Boat and the nearby mark of the course.

14.2 Bayfield City Dock Finish Lines: When Bayfield City Dock is used as one mark of the finish line, the other end will be a mark approximately 200 feet from the end of the pier in a line projected by extending Rittenhouse Avenue through the end of the pier. In the absence of a second mark in the water, all yachts will finish within approximately 200 feet of the pier along the line specified above.

## **14.0 Time Limit**

14.1 The time limit for buoy races will be three hours. Distance or point-to-point races shall not have a time limit unless announced by the Race Committee prior to the start.

## **15.0 Protests**

16.1 Rule 61.1 (a) is changed to add that a boat intending to protest shall, as soon as possible after finishing or retiring, inform the finish line Race Committee Boat of her intent to protest and the sail number(s) of the boat(s) being protested. Except in cases where damage or medical emergency forces a boat to retire, a protest is invalid when this requirement is not met and the Protest Committee shall refuse to hear the protest under rule 63.5.

16.2 Protests shall be written on US Sailing protest forms. Lacking a proper protest form, a protesting boat shall provide in writing the information required under Rule 61.2. Protests shall be submitted to the AIS Race Judge or AIS Fleet Captain.

16.3 Time limit for filing protests shall be one hour after the docking of the RC Boat after the last race of the day. This Instruction applies regardless of the hearing schedule.

16.4 Notices will be posted within 60 minutes of the protest time limit to inform competitors of hearings in which they are parties or named as witnesses. Hearings will be scheduled for the day the protests were received and in the order the protests were received. In unusual circumstances and with sufficient notice, the Protest Committee may schedule a hearing for a different day, time or order.

16.5 Notices of hearings shall be posted on the official AIS Notice Board in Bayfield. Notices of hearings may also be posted on the WYC Internet Site at [www.wyc.org](http://www.wyc.org). Internet postings, if any, are informational only.

16.6 Postponement of a hearing by a party: a party to a protest may request postponement of a hearing for any reason by contacting the Fleet Captain (listed on the front page of these instructions). Only one postponement by a party will be permitted. Instruction 16.10 will thereafter apply

16.7 Withdrawal of a Protest: when desiring to withdraw a protest already filed, the protesting party shall first contact the other party(s) to the protest to seek agreement, then shall contact the AIS Race Judge or AIS Fleet Captain. The Race Judge or Fleet Captain then may elect to approve the request to withdraw in accordance with Rule 63.1.

16.8 Failure to appear: if a party to the hearing does not come to the hearing, the Protest Committee may nevertheless decide the protest in the absence of the party in accordance with Rule 63.3(b).

16.9 Ratings Protest: if a party wishes to protest their rating or the rating of a competitor, the protest form must be submitted to LM-PHRF prior the first race of a series. Any decision of LM-PHRF shall be final.

## **16.0 Scoring**

16.1 The low point scoring system, Rule A4 will apply. There are no throw outs.

## **17.0 Haul out Restrictions**

17.1 None

## **18.0 Communications**

19.1 Boats may communicate with the Race Committee via VHF radio on Channel 72, but all such communications shall be non-binding and unofficial. Visual signals shall prevail.

## 19.0 Prizes

20.1 Trophy prizes will be awarded for each Series and Cup Race based on the average number of racers in each. Average is mathematical with .5 rounded up and .49 rounded down. One prize for a 4 or fewer average number of racers; two prizes for 5 or 6; three prizes for 7 through 11; four prizes for 12 through 15; or five prizes for 16 or more average number of racers.

20.2 Participation prizes will be awarded to each boat that earns a trophy, or that finishes any 15 races.

20.3 Additional places may be awarded at the discretion of the Trophy Chairman and budget.

## 2012 AIS Sailing Schedule

(All AIS morning starts 11:00 unless noted otherwise)

### Spring Series 5 Races

May 26th 2 races  
May 27th 2 races  
May 28th 1 race optional 2<sup>nd</sup> race weather and time permitting

### Summer Series 10 Races

June 30th 1 race Around the Islands 10:00 start  
July 2nd 2 races\*  
July 3rd 2 races\*  
July 4th 2 races\*  
July 5th 2 races\*  
July 6th 1 race\*

\*racing schedule and number of races TBD by Race Week Committee

### Fall Series 5 Races

Sept 1st 1 race Around Madeline 10:30 start  
Sept 2nd 2 races  
Sept 3rd 2 races

#### Single/double handed race

Sept 15th (not part of Championship series)

#### Bayfield Cup 2 Races

Sept 22nd Race to Saxon (depth permitting)  
Sept 23rd Race from Saxon to Bayfield

**Illustration B**

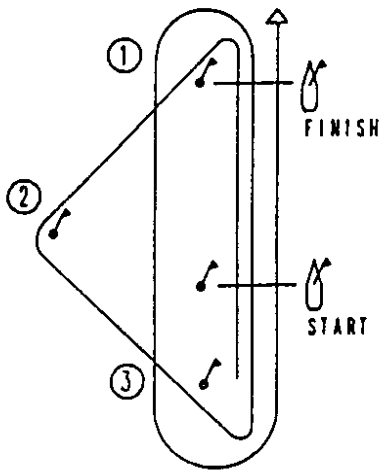

**Olympic O-1**

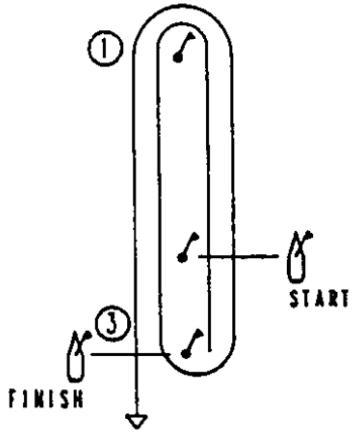

**Windward Leeward WL2**



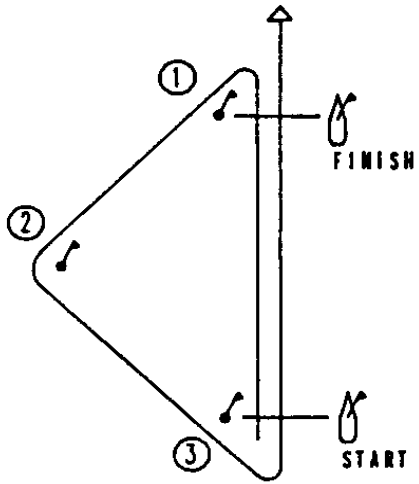

Triangle T1 1/3