



160th NYYC ANNUAL REGATTA

Presented by ROLEX

June 13-15, 2014
Newport, Rhode Island



SAILING INSTRUCTIONS incorporating Amendments #1-2

1 RULES

- 1.1 The regatta will be governed by the rules as defined in the *Racing Rules of Sailing* (RRS). Appendix D, Team Racing Rules, will not apply for the Rolex Cup or Great Corinthian Trophy team events.
- 1.2 The Annual Regatta website can be found at <http://nyyc.org/yachting/racing/160th-annual-regatta>.
- 1.3 **Safety Equipment Requirements:** All yachts shall comply with the US Nearshore section of the NOR Addendum 1 – US Safety Equipment Requirements (USSER) and shall comply with their class rules, where applicable.
 - USSER 2.4.2 through 2.4.8 regarding Hull and Structure: Lifelines shall apply, except that yachts not normally rigged with lifelines are exempt for these requirements and shall wear approved PFDs at all times while racing. This requirement does not apply to Classics, 6 Metres or 12 Metres, although they are strongly encouraged to wear PFDs.
 - In the event of a conflict between these Requirements and applicable class rules, the class rules shall apply.
- 1.4 The US SAILING Prescriptions to the RRS that are posted as NOR Addendum 2 on the Annual Regatta website shall apply.
- 1.5 The NYYC Classics Rules that are posted as NOR Addendum 3 shall apply to all yachts sailing in the Classics or Spirit of Tradition classes.
- 1.6 The Protest Committee may impose suitable penalties, other than disqualification, for violations of the ISAF Offshore Special Regulations or other non-Part 2 rules. This changes RRS 64.1.
- 1.7 Etchells – Special sailing instructions for racing in the Etchells Fleet are posted as SI Appendix D – Red Fleet Drop Mark Races.
- 1.8 The current class rules shall apply to all yachts racing as a one-design class, except as noted in these sailing instructions.
- 1.9 Swan 42 Class – For any Swan 42 electing to sail in the Swan 42 class in the Around-the-Island Race on Friday, June 13, the following will apply:
 - a) Yachts that comply with the Swan 42 Class One-Design rules will be scored as a one-design class.
 - b) Any Swan 42 that, when sailing in Class one-design configuration, has a valid IRC certificate, will also be “double-scored” in the overall IRC fleet and is eligible for the overall IRC award.
 - c) A Swan 42 that has a valid IRC certificate, but does not comply with the Swan 42 Class One-Design rules, shall be placed in an IRC class.
- 1.10 Melges 32 Class – Racing conducted by the Class on Friday, June 13, will be included in the overall scores of a three-day series including all races on Friday, Saturday and Sunday. If six or more races are completed, each boat’s worst score shall be excluded.
- 1.11 The Onion Patch Series 2014 includes races in the 160th NYYC Annual Regatta presented by Rolex for those yachts that have also entered the Series. Details can be found in the Notice of Series at: <http://www.onionpatchseries.com/images/pdf/2014prelimnor.pdf>.
- 1.12 As the ORR Navigators Class is part of the Onion Patch Navigators Series, yachts are allowed to use sails and equipment as permitted in the Newport Bermuda Race.

2 ENTRIES

- 2.1 Eligible yachts shall enter by completing online registration with the Organizing Authority on the Annual Regatta website. Eligibility requirements for yachts and method of entry are detailed in the Notice of Race.

- 2.2 Team entries for the Rolex Cup and the Great Corinthian Trophy shall be entered on the separate entry forms posted on the Annual Regatta website. There is no entry fee for either team event.

3 NOTICES, COMPETITOR INFORMATION AND SIGNALS MADE ASHORE

- 3.1 Notices, including race results, amendments and protest hearing schedules, shall be posted on the Official Notice Board located in the courtyard of the NYYC Sailing Center at Harbour Court. This information may also be posted on the Annual Regatta website.
- 3.2 Flag signals will be flown from the flagpole at Harbour Court.
- 3.3 Any change to the sailing instructions will be posted before 0900 on the day it will take effect, except that any change to the schedule of races will be posted by 2000 on the day before it will take effect. Flag “Lima” will be flown to signify such posting.
- 3.4 When Pennant “AP” is displayed ashore, “one minute” is replaced with “not less than one hour” in Race Signal “AP”.
- 3.5 Signals designating the rendezvous locations will be displayed at 0900 on Friday, Saturday and Sunday from the flagpole at Harbour Court. The Race Committee will endeavor to announce the locations as described in SI 6 at that time over VHF Channel 72. The failure to make this announcement or for a yacht to hear this announcement will not be grounds for redress. This changes rule 62.1(a).
- 3.6 After the rendezvous locations and any other regatta announcements have been made, Race Committee Signal Boats will monitor and communicate with their respective fleets on the VHF channels published in SI 4.3.

4 CLASSES AND IDENTIFICATION

- 4.1 The Organizing Authority will divide yachts into classes.
- a) For the Around-the-Island Race on Friday, June 13, classes will be assigned a numeral designation and be designated the BLUE Fleet.
 - b) For racing on Saturday and Sunday, classes will be assigned a numeral designation and placed in one of four fleets (Blue, White, Green, Red).
- 4.2 **Scratch Sheets** - There will be a separate scratch sheet for the Around-the-Island Race on Friday and for each fleet (Blue, White, Green, Red) racing on Saturday and Sunday. Note that a yacht may be in different classes in the different portions of the Annual Regatta. The scratch sheets will be distributed at registration, posted on the Official Notice Board and posted on the Annual Regatta website.
- 4.3 **VHF Channels** - The Race Committee VHF channels for each fleet are shown below:
- | | | | |
|------------------------|-------------|----------------|---|
| a) Friday, June 13 | Blue Fleet | VHF Channel 72 | (All classes in Around-the-Island Race) |
| b) Sat/Sun, June 14-15 | Blue Fleet | VHF Channel 72 | |
| | White Fleet | VHF Channel 69 | |
| | Green Fleet | VHF Channel 71 | |
| | Red Fleet | VHF Channel 77 | |
- 4.4 **Backstay Flags** – Each yacht shall display the numeral flag corresponding to her class designation, as shown on the scratch sheet, from her backstay approximately six feet above the deck and above the Rolex flag, from the warning signal of the first class in her fleet until she is no longer racing. Yachts without a permanent backstay shall conspicuously display these flags in an alternate position in the aft part of the yacht.
- 4.5 **Bow Stickers and Flags** - Each yacht shall display the Rolex backstay flag and bow stickers provided at registration while racing. Wooden yachts and Classics are not required to apply the bow stickers.

5 SCHEDULE OF RACES

- 5.1 The Around-the-Island Race will be sailed on Friday, June 13, and is open to all eligible yachts. This race will be scored separately from the racing on Saturday and/or Sunday except as specifically requested by a one-design class to the OA. Course signals will be made on Friday, June 13, at 1200. Classes may not start in numerical order. See SI 9.2 and SI Appendix A.
- 5.2 The TWO-DAY Series will be held on Saturday and Sunday, June 14-15. All races will count in the TWO-DAY Series. The course signals will be made at 1100 for all fleets on Saturday, June 14 and Sunday, June 15.
- 5.3 There will be one NAVIGATOR Race on Saturday, June 14 and one on Sunday, June 15. Each race will be scored separately. The first course signals will be at 1100 each day.

5.4 No warning signal shall be made after 1500 on Sunday, June 16.

6 RENDEZVOUS LOCATIONS

Fleet rendezvous locations are listed below and will be designated as described in SI 3.5. See SI Appendix E – NYYC Primary Race Areas.

Rhode Island Sound:

- Area “A” - in the vicinity of 160° for 1.2 NM from R “2” QR Whistle marking Brenton Point
- Area “B” - in the vicinity of 120° for 2.5 NM from R “2” QR Whistle marking Brenton Point
- Area “C” - in the vicinity of 225° for 2.0 NM from R “2” QR Whistle marking Brenton Point
- Area “D” - in the vicinity of 200° for 3.5 NM from R “2” QR Whistle marking Brenton Point
- Area “E” - in the vicinity of 165° for 2.5 NM from R “2” QR Whistle marking Brenton Point
- Area “F” - in the vicinity of 150° for 4.5 NM from R “2” QR Whistle marking Brenton Point

Newport Harbor and near Newport Bridge:

- Area “M” - in the vicinity of R “12” west of Rose Island
- Area “O” - in the vicinity of Potter Cove (just north of west end of Newport Bridge)

North of Newport Bridge:

- Area “R” - in the vicinity of 200° for 0.5 NM from Halfway Rock
- Area “T” - in the vicinity of G “7” QG off Quonset Point

7 CHECK-IN AND RETIREMENT

- 7.1 Prior to the warning signal for the first race each day, all yachts shall check in with the Race Committee Signal Boat by passing astern on starboard tack and announcing their sail number. The Race Committee will acknowledge by responding with the number heard.
- 7.2 Yachts retiring are requested to inform the Race Committee on their fleet VHF channel or by calling (401) 845-9633.

8 COURSES & MARKS

The courses and marks for each section of the Annual Regatta are described in the SI Appendices as shown:

Friday, June 13	Around-the-Island Race	SI Appendix A	All classes
Sat/Sun, June 14-15	South Bay Race Chart Courses	SI Appendix B	Green, Navigators, S Class
	Drop Mark Courses	SI Appendix C	Blue & White
	Red Fleet Drop Mark Courses	SI Appendix D	Etchells

9 THE START

- 9.1 Races will be started in accordance with rule 26.
- 9.2 The intended order of start for the Around-the-Island Race on Friday, June 13, will be included in the Race Committee’s announcement on VHF Channel 72 at 0900. Classes may not start in numerical order. The Race Committee may combine two or more classes into one start by displaying multiple class flags at the Warning Signal. The Race Committee will endeavor to announce the next class(es) to start on VHF Channel 72.
- 9.3 A yacht starting later than 20 minutes after her starting signal will be scored Did Not Start. This changes rule A4.
- 9.4 The starting line will be between a staff displaying an orange flag on the Race Committee Signal Boat and the course side of the port-end starting mark.
- 9.5 Yachts whose warning signal has not been made shall keep clear of the starting area.
- 9.6 Sample sequence:

Friday, June 13	Sat/Sun, June 14-15	
1200	1100	Course Signals
1205	1105	Warning for first class
1206	1106	Preparatory for first class
1210	1110	Start for first class, Warning for second class
1211	1111	Preparatory for second class
1215	1115	Start for second class, Warning for third class
1216	1116	Preparatory for third class
1220	1120	Start for third class, etc.

10 INDIVIDUAL RECALLS

The Race Committee will endeavor to hail each premature starter over their respective fleet VHF channel. Failure to make such an announcement, nor the timing or order of any announcement, shall not be grounds for redress. This changes rule 62.1(a).

11 THE FINISH

The finishing line is described in the SI Appendix for each section of the Annual Regatta.

12 GOVERNMENT BUOYS

Government buoys have no required side except when specified as marks of the course. Caution should be exercised for safe navigation.

13 PENALTY SYSTEM

- 13.1 If class rules specify a penalty, a yacht that may have broken a rule of Part 2 while racing may take a penalty at the time of the incident as provided in her class rules.
- 13.2 If the class rules do not specify a penalty, rule 44.1 is changed so that a yacht has the choice between penalty systems and the Two-Turns Penalty is replaced by the One-Turn Penalty. A yacht may choose either to:
 - a) take a One-Turn Penalty in accordance with rule 44.2; or
 - b) take a Scoring Penalty in accordance with rule 44.3.
- 13.3 A yacht that has taken a penalty shall, no later than the end of protest time, either: a) complete a penalty acknowledgement form available from the Jury Secretary and file it with the Jury Secretary; or b) submit the online penalty acknowledgement form found on the regatta website.

14 TIME LIMIT

- 14.1 The time limit to sail the course and finish is as follows:
 - a) For the Around-the-Island Race courses – five hours.
 - b) For a South Bay Racing Chart course – four hours.
 - c) For a drop mark course – three hours.
 - d) For a drop mark course for the Red Fleet – two hours.
- 14.2 Except as noted in SI Appendix D (Red Fleet), yachts failing to finish within 60 minutes of the first yacht in her class to sail the course and finish, or within the time limit, whichever is later, will be scored Did Not Finish (DNF) and scored points as described in SI 16.4. This changes rules 35 and A4.

15 PROTESTS AND REQUESTS FOR REDRESS

- 15.1 It is requested that yachts intending to protest report both their intention and the yacht being protested to the Race Committee on the fleet VHF channel immediately after finishing or withdrawing from the race.
- 15.2 Written protests or requests for redress shall be submitted to the Jury Secretary in the NYYC Sailing Center as soon as possible, but not later than one hour after the Race Committee Signal Boat for that fleet has docked. The time limit for filing a protest will be posted on the Official Notice Board.
- 15.3 Protest notices will be posted as soon as possible on the Official Notice Board.
- 15.4 Protest hearings will take place at the NYYC Sailing Center as soon as possible after the notices are posted. The Jury will attempt to hear protests in the order of receipt. Representatives of yachts who are parties to a hearing shall remain on call in the vicinity of the protest rooms.
- 15.5 When a yacht has been involved in an incident that may be subject to protest, it is her responsibility to check the protest notices at the end of the protest filing time to see if she is cited in a protest. Failure of any yacht to appear when called for a hearing will be considered by the Jury as grounds for proceeding under rule 63.3(b).
- 15.6 Rule 63.5 is changed by adding, “A protest involving contact may be heard by the Protest Committee even though the requirements of rule 61.1(a) and 61.3 have not been fulfilled.”
- 15.7 Breaches of SIs 4.4, 4.5, 7, 9.5 and 18.2 will not be grounds for a protest by a yacht. This changes rule 60.1(a).
- 15.8 A violation of SI 18.2 will be considered “a gross breach of a *rule*” under rule 69.1(a).

- 15.9 On the last scheduled day of racing only, a written request for reopening a hearing shall be delivered to the Jury Secretary:
- Within the protest time limit if the requesting party was informed of the Protest Committee's decision on the previous day; or
 - No later than 30 minutes after the requesting party was informed of the Protest Committee's decision on that day; or
 - If no races are held on the last scheduled day of racing, within one hour after racing has been abandoned.
- This changes rule 66.
- 15.10 On the last scheduled day of racing, a request for redress based on a Protest Committee decision shall be delivered in writing no later than 30 minutes after the decision was posted. This changes rule 62.2.

16 SCORING

- 16.1 See SI 5. The Around-the-Island Race on Friday, June 13, will be scored separately from racing on Saturday and Sunday. The Navigators Races will be scored separately and there is no cumulative score for the two days.
- 16.2 In the Two-Day Series, a yacht's series score will be the total of her race scores. There will be no drop race. This changes rule A2.
- 16.3 One race is required to be completed to constitute a series.
- 16.4 Yachts that have started and fail to finish within the time limit for any reason, shall, without a hearing, be scored by the Race Committee with points equal to the number of yachts in her class that have sailed the course and finished within the time limit, plus two. This changes rule A4.1, A4.2, and A5.
- 16.5 Teams competing for team trophies will be scored in accordance with the Notice of Race.

17 PRIZES

Prizes will be awarded as described in the Notice of Race.

18 NOTES

- 18.1 Competitors are reminded that Narragansett Bay and its approaches are considered restricted channels for commercial traffic and other vessels restricted in their ability to maneuver. Competitors must comply with the government right-of-way rules when in proximity to commercial or privileged marine traffic.
- 18.2 In the event there is racing in Narragansett Bay, competitors should be aware of heightened security around the Navy base in Newport just to the north of the Newport Jamestown Bridge. The area to the east of a line defined by a series of white buoys marking the Newport Security Zone along the coast of the Naval Facilities from Coasters Harbor to the breakwater at the north end of Coddington Cove shall rank as an obstruction. Yachts shall not enter this area. A Navy patrol boat monitors the area and vessels navigating in the Exclusionary Zone may face action by Coast Guard and Naval authorities.
- 18.3 All times herein are Eastern Daylight times. Bearings are in degrees magnetic and are approximate. Distances used herein are expressed in nautical miles (when not otherwise defined) and are approximate.

18.4 Newport Tides

Day	Date	High Tide	Height	Low Tide
Friday	June 13	0830	3.9 ft.	1355
Saturday	June 14	0921	4.1 ft.	1446
Sunday	June 15	1014	4.1 ft.	1539

18.5 For further information please contact:

New York Yacht Club, Harbour Court
 5 Halidon Avenue
 Newport, RI 02840
 Tel: 401-845-9633
 Fax: 401-846-3303
 Email: sailingoffice@nyyc.org
 Website: <http://nyyc.org/yachting/racing/160th-annual-regatta>

SAILING INSTRUCTIONS

Appendix A – AROUND-THE-ISLAND RACE

Friday, June 13

A1 ORDER OF START

- A1.1 The intended order of start for the Around-the-Island Race on Friday, June 13, will be included in the Race Committee's announcement on VHF Channel 72 at 0900. Classes may not start in numerical order. The Race Committee may combine two or more classes into one start by displaying multiple class flags at the Warning Signal. The Race Committee will endeavor to announce the next class(es) to start on VHF Channel 72.
- A1.2 The starting mark will be an ORANGE tetrahedron buoy.

A2 COURSES FOR AROUND-THE-ISLAND RACE

- A2.1 The Race Committee will use VHF channel 72 for the Around-the-Island Race on Friday, June 13.
- A2.2 The flag(s) designating the course to be sailed will be displayed at Course Signals. The Race Committee will endeavor to announce the designated courses over VHF channel 72. Failure to make such an announcement shall not be grounds for redress. This changes rule 62.1(a).
- A2.3 Special Mark "U"
- The Race Committee may add a new first mark to any course by displaying flag "U".
 - If Mark "U" is used, there will be either a Green or Red flag displayed below "U" to designate the direction to be rounded. Mark "U" is to be rounded either to STARBOARD (Green flag below "U"), or to PORT (Red flag below "U").
 - The distance and bearing to Mark "U" will be signaled using flags displayed on poles. Flag "U" with the Green or Red flag will be flown forward, followed by the three numeral pennants designating the magnetic bearing to the first mark, followed by the two numeral pennants designating distance (nautical miles and tenths) to Mark "U".
 - Mark "U" will be a YELLOW tetrahedron buoy.
- A2.4 **Course "J"**, clockwise around Conanicut Island:
- RG "NR" Bell 650 yards SW of Beavertail Point to starboard
 - The center span of the Jamestown Verrazano Bridge
 - C "5" 1,250 yards NW of Conanicut Point to starboard
 - R "2" Fl R 4 Sec Bell 900 yards NE of Conanicut Point to starboard
 - The center span of the Newport Jamestown Bridge
 - Pass to the west of R "12" off Rose Island
 - Finish off Fort Adams (see SI Appendix A 2.7 below)
- A2.5 **Course "JR"** - if Flag "R" is flown beneath Flag "J", the Around Conanicut Island race shall be sailed in the reverse direction (counter-clockwise), with the above rounding marks passed to port, finishing off Fort Adams.
- Pass to the west of R "12" off Rose Island
 - The center span of the Newport Jamestown Bridge
 - R "2" Fl R 4 Sec Bell 900 yards NE of Conanicut Point to port
 - C "5" 1,250 yards NW of Conanicut Point to port
 - The center span of the Jamestown Verrazano Bridge
 - RG "NR" Bell 650 yards SW of Beavertail Point to port
 - Finish off Fort Adams (see SI Appendix A 2.7 below)
- A2.6 For the purposes of rule 32.2(c), the center spans of the Jamestown Verrazano Bridge and the Newport Jamestown Bridge shall be considered gates.

- A2.7 The finishing line for the Around-the-Island Race Courses will be between a staff displaying an orange flag on a Race Committee Boat and the finishing mark, which will be a YELLOW tetrahedron buoy. The finishing line will be located approximately 0.25 NM north of the Fl R 6 sec Horn “2” on the northern point of Fort Adams.
- A2.8 In fog at the finish, the Race Committee Boat may ring a bell rapidly, for approximately 5 seconds, at intervals. The same Race Committee Boat may or may not start and finish each race.

SAILING INSTRUCTIONS

Appendix B – SOUTH BAY RACE CHART COURSES

Saturday-Sunday, June 14-15

The Green and Navigator Fleets, including 12M, Classics, 6M, and the Navigator Race classes (PHRF, ORR) will race on course(s) using the South Bay Race Chart.

B1 COURSES USING SOUTH BAY RACING CHART

B1.1 Special courses will be designated using buoys (as described on the 2012-2014 South Bay Race Chart provided at registration and as described in SI B2.3) or the course as described in SI B1.2. (Note: Designated courses from the back of the South Bay Race Chart will not be used.)

- a) The Race Committee will list the marks on a white board in the order to be rounded and the required side to leave the mark using the designations on the 2012-2014 South Bay Race Chart.
- b) **Newport Bridge** – Yachts shall pass through the **center span only** for any course passing under the Newport Bridge. For the purposes of rule 32.2(c), the center span shall be considered a gate.
- c) Special Mark “U”
 - The Race Committee may add a first mark to any course by displaying flag “U”.
 - If Mark “U” is used, there will be either a Green or Red flag displayed below “U” to designate the direction to be rounded. Mark “U” is to be rounded either to STARBOARD (Green flag below “U”), or to PORT (Red flag below “U”).
 - The distance and bearing to Mark “U” will be signaled using flags displayed on poles. Flag “U” with the Green or Red flag will be flown forward, followed by the three numeral pennants designating the magnetic bearing to the first mark, followed by the two numeral pennants designating distance (nautical miles and tenths) to Mark “U”.
 - Mark “U” will be a YELLOW tetrahedron buoy.

d) Special Mark “L”

- The Race Committee may set a mark “L” which will be set approximately 0.1 nm to windward of the Race Committee signal boats.
- If “L” is used, it will be listed as a mark as described in SI B1.1(a).

e) The course will be:

Start

- Special Mark “U” if used
- Round the marks in the designated order leaving each mark to the designated side
- Finish

f) The finishing mark will be on the opposite side of the Race Committee Signal Boat from the starting mark.

B1.2 **Course “PI”** – if the Race Committee designates the course “PI”, the course will be around Prudence Island in either direction (you choose) as follows:

- Start
- Special Mark “U” if used
- Leave Prudence Island, including RG N at the northern end and R “8” northwest of Patience Island, to port; OR



Course “PI”

- Leave Prudence Island, including R “8” northwest of Patience Island and RG N at the northern end, to starboard.
- Finish

B1.3 After starting and before finishing, the starting and finishing lines are designated as obstructions and shall not be crossed.

B2 MARKS

B2.1 Mark “U”, if used, will be a YELLOW tetrahedron buoy. The starting mark will be a GREEN tetrahedron buoy. The finishing mark will be a PINK tetrahedron buoy.

B2.2 Special NYYC Temporary Inflatable Race Marks 16 and 17 as designated on the 2012-2014 South Bay Race Chart, if used, will be ORANGE tetrahedron buoys.

B2.3 **Additional Marks** - the following additional marks not shown on the 2012-2014 South Bay Race Chart may also be used. This diagram should not be used for navigation. See charts 13223, 13226 and 13224 for more detail.

SP	RGR “SP” Fl (2 +1) R 6s BELL approx. 0.75 NM northeast of Sandy Pt. on Prudence I	<i>(41° 36.93’ N, 71° 17.59’ W)</i>
G3	G “3” Fl G 4s approx. 0.5 NM southwest of Popasquash Neck	<i>(41° 38.53’ N, 71° 18.46’ W)</i>
MH	RGR “MH” Fl (2 +1) R 6s GONG in Mt. Hope Bay	<i>(41° 39.54’ N, 71° 14.04’ W)</i>
BH	RGR N "Middle Ground Buoy" approx. 0.8 NM north of Hog Island in Bristol Harbor	<i>(41° 39.68’ N, 71° 16.87’ W)</i>
HI	G “3” Fl G 4s BELL approx. 0.4 NM south southeast of Hog Island	<i>(41° 37.79’ N, 71° 16.29’ W)</i>

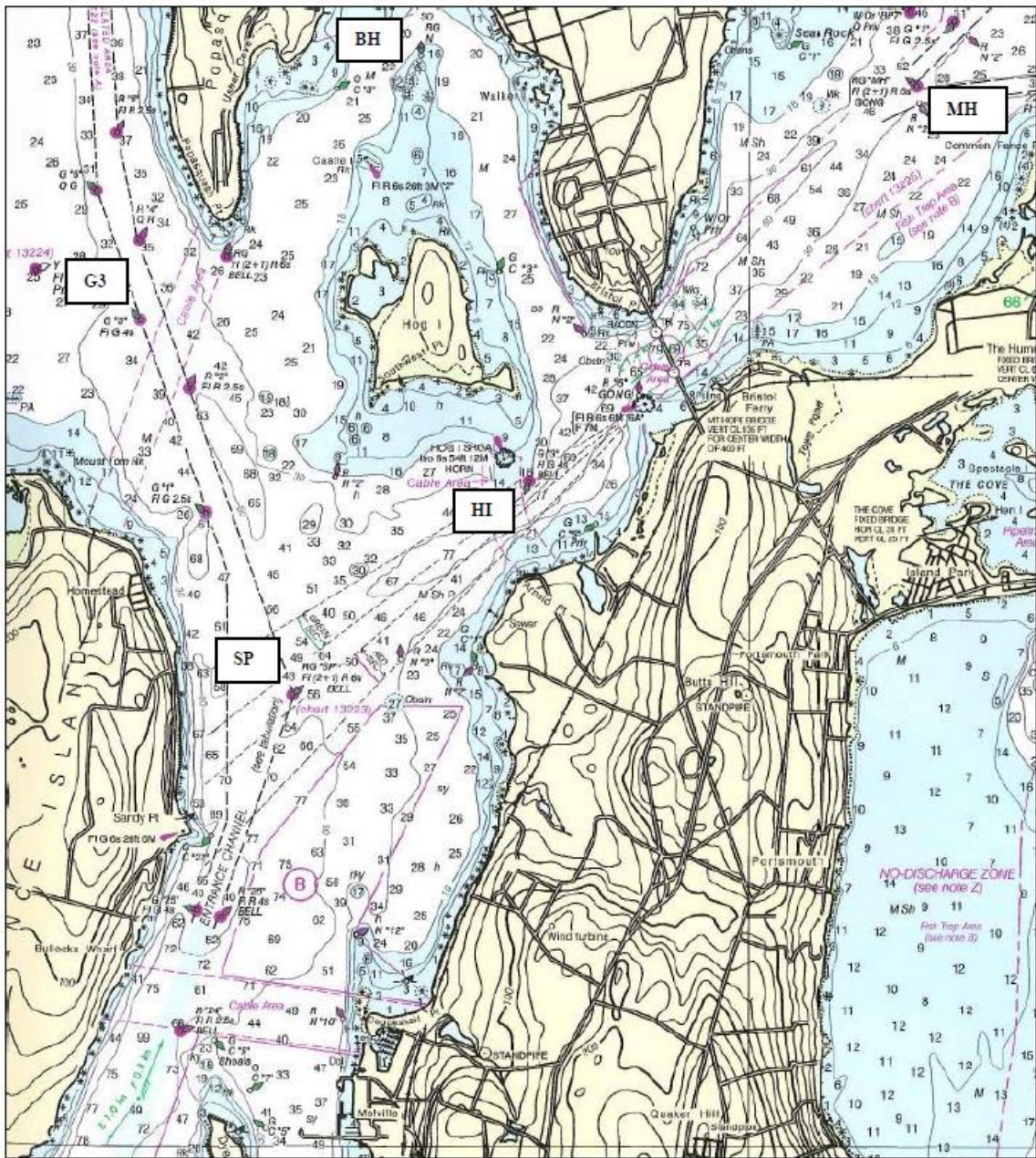

SAILING INSTRUCTIONS

Appendix C – DROP MARK RACES

Saturday-Sunday, June 14-15

The Blue and White fleets on Saturday and Sunday will race on courses as described below:

C1 COURSES FOR DROP MARK RACES

C1.1 Course Diagrams

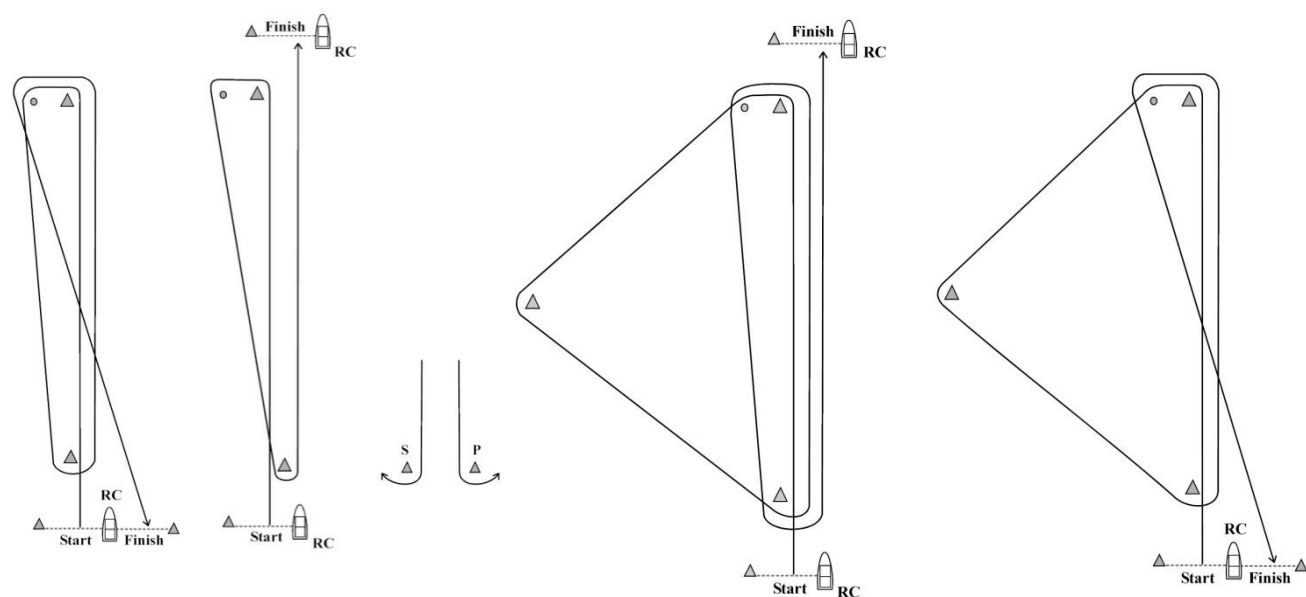

Course "W"
Even # legs

Course "W"
Odd # legs

Gate
Marks

Course "O"

Course "K"

C1.2 **Course "W"** is a Windward/Leeward course with a windward offset mark. A numeral pennant indicating the number of **LEGS** to be raced will be flown beneath Flag "W". The distance between the windward mark and the offset mark shall not count as a leg for the purposes of indicating the number of legs.

C1.3 **Course "O"** is a Triangle/Windward/Leeward/Windward course.

C1.4 **Course "K"** is a Triangle/Windward/Leeward course.

C1.5 The leeward mark for Courses "W", "O", and "K" will be an inflatable mark(s) set approximately 0.10 NM to windward of the starting line. A gate mark may be used for Course "W".

C1.6 The course designation, distance and bearing to the windward mark will be signaled using flags displayed on poles. The course designation will be flown forward, followed by the three numeral pennants designating the magnetic bearing to the first mark, followed by the two numeral pennants designating distance (nautical miles and tenths) to the first mark.

C1.7 Marks, including the windward offset mark, shall be rounded in order and left to port, except that a gate, when used, shall be rounded as described rule 28.1(c).

C1.8 There will be a windward offset mark adjacent to the windward mark for all drop mark courses except as noted for the Blue Fleet in SI C1.9.

C1.9 This instruction applies to the **BLUE FLEET** only:

- For course “W” with an even number of legs, the Race Committee may set a long windward mark and a short windward mark.
- The distance displayed will be to the SHORT windward mark. The long windward mark will be on the same bearing at a distance of 1.0 NM beyond the short windward mark.
- The long windward mark will have a black band and there will be no offset mark.
- If flag “U” is displayed below the course signals, that class will use the LONG windward mark for each weather leg in that race. If flag “U” is NOT displayed below the course signals, that class will use the SHORT windward mark for each weather leg in that race.

This changes the diagrams in SI Appendix C 1.1, as well as SI Appendix C 1.2, 1.7, 1.8 and 2.2.

C2 MARKS FOR COURSES “W”, “O”, and “K”:

C2.1 Marks will be inflatable tetrahedron buoys as follows:

<u>Fleet</u>	<u>Original marks</u>	<u>Change marks</u>	<u>Starting</u>	<u>Finishing</u>
BLUE	Yellow	Orange	Orange	Yellow
WHITE	Orange	Yellow	Yellow	Orange

C2.2 Offset marks will be small round orange buoys.

C3 COURSE CHANGE

C3.1 In addition to the requirements in rule 33, the Race Committee will attempt to announce any course change on their respective fleet VHF channel. Failure to make such an announcement shall not be grounds for redress. This changes rule 62.1(a).

C3.2 The new mark will be a different color (orange or yellow) from the original mark as described in SI Appendix C 2.1. For a subsequent change, the new mark will be the same as the original mark.

C4 THE FINISH

C4.1 The finishing line will be between a staff displaying an orange flag on a Race Committee Boat and the finishing mark.

- a) For Course “W”, with an odd number of legs, and Course “O”, the finish line will be located approximately 0.1 NM to windward of the windward mark.
- b) For Course “W”, with an even number of legs, and Course “K”, the finish line will be located approximately 0.1 NM to leeward of the leeward mark and the finishing mark will be on the opposite side of the Race Committee Signal Boat from the starting mark. See diagrams in SI Appendix C 1.1.

C4.2 If a subsequent race is to be sailed, the finish line Race Committee Boat intends to fly Pennant “Second Substitute” with the Blue “On-Station” signal at the finish. If a Class Flag is displayed below Pennant “Second Substitute” the subsequent race is for that class(es) only. In addition, the Race Committee will attempt to announce a subsequent race on their respective fleet VHF channel.

C4.3 In fog at the finish, the Race Committee Boat may ring a bell rapidly, for approximately 5 seconds, at intervals. The same Race Committee Boat may or may not start and finish each race.

SAILING INSTRUCTIONS

Appendix D – RED FLEET DROP MARK RACES

Saturday-Sunday, June 14-15

It is the intention of the Race Committee to use the drop mark course described below for one-design classes on the Red Fleet circle.

D1 COURSES FOR DROP MARK RACES

D1.1 Course Diagram

D1.2 **Course** – The Race Committee Signal Boat will signal the Course Number, the approximate magnetic bearing and distance in nautical miles from the Race Committee Signal Boat to Mark 1.

Course 2: Start - 1 - 1a – Finish (Downwind)

Course 3: Start - 1 - 1a - Gate – Finish (Upwind)

Course 4: Start - 1 - 1a - Gate - 1 - 1a – Finish (Downwind)

Course 5: Start - 1 - 1a - Gate - 1 - 1a - Gate – Finish (Upwind)

Course 6: Start - 1 - 1a - Gate - 1 - 1a - Gate- 1 - 1a – Finish (Downwind)

D1.3 (a) Marks 1 and 1a shall be rounded to port. Mark 1a is an offset mark and will be positioned to port of Mark 1.

(b) In the event Mark 1a is not in place the boats shall round Mark 1 to port

(c) When the windward mark is changed in accordance with SI D3, there will not be an offset mark.

D1.4 (a) In the event that a Gate is not in place, boats shall round the existing Leeward mark to port.

(b) Except when there is a change of course, the Gate will be positioned approximately to windward of the Race Committee Signal Boat.

(c) The Gate may be set after the starting signal.

D1.5 Except when there is a change of course:

(a) The Finish for courses 2, 4 and 6 will be downwind of the Gate; and

(b) The Finish for courses 3 and 5 will be upwind of Mark 1.

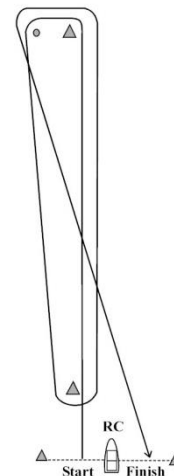

D2 MARKS

D2.1 Marks will be inflatable buoys as follows:

<u>Fleet</u>	<u>Original marks</u>	<u>Offset mark</u>	<u>Change mark</u>	<u>Starting</u>	<u>Finishing</u>
RED	Yellow tetrahedron	Orange cylinder	Orange tetrahedron	Orange tetrahedron	Yellow tetrahedron

D2.2 The Race Committee may use a race committee boat in place of the port-end starting mark in which case the port end of the starting line will be a staff displaying an orange flag.

D3 COURSE CHANGE

In addition to the requirements in rule 33, the Race Committee will attempt to announce any course change on VHF channel 77. If the direction of the leg is changed, it will be signaled in accordance with rule 33(a)(2). Failure to make such an announcement shall not be grounds for redress. This changes rule 62.1(a).

D4 THE FINISH

- D4.1 The finishing line will be between a staff displaying an orange flag on a Race Committee Boat and the finishing mark. In courses 2, 4 and 6, the finishing mark will be on the opposite side of the Race Committee Signal Boat from the starting mark. See diagram in SI Appendix D 1.1.
- D4.2 The Race Committee will attempt to announce a subsequent race on VHF channel 77.
- D4.3 In fog at the finish, the Race Committee Boat may ring a bell rapidly, for approximately 5 seconds, at intervals. The same Race Committee Boat may or may not start and finish each race.

D5 TIME LIMIT

- D5.1 The time limit shall be 2 hours.
- D5.2 Boats failing to finish within 20 minutes after the first boat sails the course and finishes within the time limit will be scored points for the finishing place equal to the number of boats that finished that race plus 2. This changes RRS 35 and A4.

SAILING INSTRUCTIONS

Appendix E – NYYC PRIMARY RACE AREAS

